

# HTF3000LF Temperature and Humidity Module

## DESCRIPTION

Based on the rugged HS1101LF humidity sensor, HTF3000LF is a dedicated humidity and temperature transducer designed for OEM applications where a reliable and accurate measurement is needed. It features a miniature connector for easy, cost-effective mechanical mounting. Direct interface with a micro-controller is made possible with the module's linear frequency output.



## FEATURES

- ◆ One of the smallest humidity/temperature modules on the market
- ◆ Compliant with RoHS regulation and most of Lead Free Soldering Process
- ◆ Stable, proportional frequency output from 0 to 100% RH
- ◆ Calibrated within +/- 3% RH @ 55% RH at 3.30 RH
- ◆ High quality thermistor
- ◆ Stable characteristics with temperature
- ◆ High reliability and long term stability

### Humidity Sensor Specific Features

- ◆ Instantaneous De-Saturation After Long Periods in Saturation Phase
- ◆ Fast Response Time
- ◆ High Resistance to Chemicals
- ◆ Not Affected by Water Immersion
- ◆ Part could be washed with distilled water
- ◆ Patented Solid Polymer Structure

### Temperature Sensor Specific Features

- ◆ 10 kΩ +/- 1% NTC temperature sensor
- ◆ Stable
- ◆ High Sensitivity

## maximum ratings

Ratings	Symbol	Value	Unit
Storage Temperature	T <sub>stg</sub>	-40 to 105	°C
Storage Humidity Range	RH <sub>stg</sub>	0 to 100	% RH
Supply Voltage (Peak)	V <sub>s</sub>	16	Vdc
Humidity Operating Range	RH	0 to 100	% RH
Temperature Operating Range	T <sub>a</sub>	-40 to 85	°C

# HTF3000LF Temperature and Humidity Module

Characteristics Humidity sensor (Ta = 25°C, Vs = 5.0 Vdc +/- 5%, RL > 100 KΩ unless otherwise stated)

Characteristics	Symbol	Min	Typ	Max	Unit
Relative Humidity Accuracy (10 to 95 % RH)	RH	Refer to Chart 2 on page 2			
Voltage Supply	Vs	3	3.30	16	VdC
Nominal Output @ RH = 55 % and 3.3Vdc	F <sub>out</sub>	6560	6600	6640	Hz
Current Consumption (Max at 16Vdc)	Ic		0.18	1	mA
Voltage Supply Influence (3 to 7Vdc)	RH		+/-1		% RH
Averaged Sensitivity from 33 % to 75 % RH	ΔF <sub>out</sub> / Δ RH	-10	- 12	-14	Hz/% RH
Humidity Hysteresis				+/-1	% RH
Long Term Stability			0.5		% RH/yr
Time Constant (40 to 95% RH, 2m/s, @63 %)	τ			10	s

## Relative Humidity Accuracy of HTF 3000LF

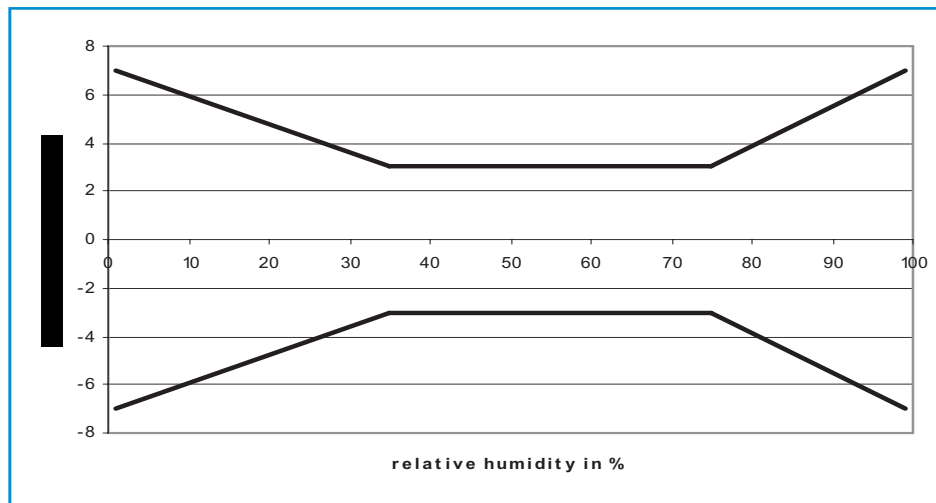

## Typical response look-up table (Polynomial Reference curve)

Modeled Signal output:  $F_{out} = 7314 - 16.9 \cdot RH + 0.0886 \cdot RH^2 - 0.000358 \cdot RH^3$  (F<sub>out</sub> in Hz and RH in %)

Modeled Reversed Equation:  $RH = 89.8 \cdot 10^{-10} \cdot F_{out}^3 - 15,7486 \cdot 10^{-5} \cdot F_{out}^5 + 0,80945 \cdot F_{out} - 1009$  (F<sub>out</sub> in Hz and RH in %)

RH (%)	1	5	10	15	20	25	30	35	40	45	50
F <sub>out</sub> (Hz)	7295	7230	7155	7080	7010	6945	6880	6820	6760	6705	6650
RH (%)	55	60	65	70	75	80	85	90	95	99	
F <sub>out</sub> (Hz)	6600	6550	6500	6450	6400	6355	6305	6260	6210	6170	

# HTF3000LF Temperature and Humidity Module

## Temperature influence on HTF3000LF humidity measurement

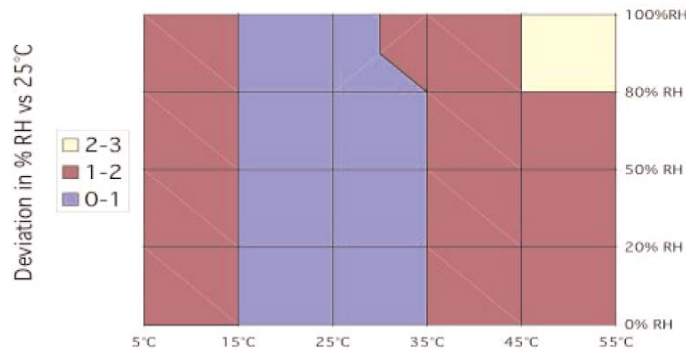

Calibration data are traceable to NIST standards through CETIAT laboratory.

## Characteristics Temperature sensor (Ta = 25°C)

Characteristics	Symbol	Min	Typ	Max	Unit
Nominal Resistance @ 25°C			10		kΩ
Beta value : B25/100	B	3346	3380	3413	
Temperature Measuring Range	Ta	- 40		85	°C
Nominal Resistance Tolerance at 25°C	Rn		1		%
B Value Tolerance	B		1		%
Response Time	τ		10		s

## Typical temperature output

Depending on the needed temperature measurement range and associated accuracy, we suggest two methods to access to the NTC resistance values.

$$① \quad R_T = R_0 \cdot e^{B \left( \frac{1}{T} - \frac{1}{T_0} \right)}$$

$R_T$  NTC resistance in Ω at temperature T in K

$R_0$  NTC resistance in Ω at rated temperature in K

$T, T_0$  Temperature in K

$B$  B value, material-specific constant of the NTC thermistor

$e$  Base of natural logarithm ( $e = 2.71828$ )

The actual characteristic of an NTC thermistor can, however, only be roughly described by the exponential relation, as the material parameter B in reality also depends on temperature. So this approach is only suitable for describing a restricted range around the rated temperature or resistance with sufficient accuracy.

② For practical applications a more precise description of the real R/T curve may be required. Either more complicated approaches (e.g. the Steinhart-Hart equation) are used or the resistance/temperature relation as given in tabulated form. The below table has been experimentally determined with utmost accuracy for temperature increments of 1 degree.

# HTF3000LF Temperature and Humidity Module

Temperature °C	Resistance (ohm)	Max. Deviation	Temperature °C	Resistance (ohm)	Max. Deviation	Temperature °C	Resistance (ohm)	Max. Deviation	Temperature °C	Resistance (ohm)	Max. Deviation
-40	195652	7921	3	23951	452	46	4754	83	89	1303	40
-39	184917	7378	4	22963	423	47	4597	82	90	1268	39
-38	174845	6874	5	22021	396	48	4446	81	91	1234	39
-37	165391	6407	6	21123	371	49	4301	80	92	1202	38
-36	156513	5974	7	20267	348	50	4161	79	93	1170	37
-35	148171	5571	8	19450	326	51	4026	77	94	1139	37
-34	140330	5197	9	18670	305	52	3896	76	95	1110	36
-33	132958	4849	10	17926	285	53	3896	75	96	1081	35
-32	126022	4527	11	17214	267	54	3651	74	97	1053	35
-31	119494	4226	12	16534	250	55	3535	73	98	1026	34
-30	113347	3947	13	15886	233	56	3423	72	99	999	34
-29	107565	3687	14	15266	218	57	3315	70	100	974	33
-28	102116	3446	15	14674	204	58	3211	69	101	949	32
-27	96978	3221	16	14108	190	59	3111	68	102	925	32
-26	92132	3011	17	13566	178	60	3014	67	103	902	31
-25	87559	2815	18	13049	166	61	2922	66	104	880	31
-24	83242	2633	19	12554	154	62	2834	65	105	858	30
-23	79166	2463	20	12081	144	63	2748	64	106	837	30
-22	75316	2305	21	11628	134	64	2666	63	107	816	29
-21	71677	2157	22	11195	125	65	2586	62	108	796	29
-20	68237	2019	23	10780	116	66	2509	60	109	777	28
-19	64991	1890	24	10382	108	67	2435	59	110	758	28
-18	61919	1770	25	10000	100	68	2364	58	111	740	27
-17	59011	1658	26	9634	100	69	2294	57	112	722	27
-16	56258	1553	27	9284	100	70	2228	56	113	705	26
-15	53650	1454	28	8947	100	71	2163	55	114	688	26
-14	51178	1363	29	8624	99	72	2100	54	115	672	25
-13	48835	1277	30	8315	99	73	2040	53	116	656	25
-12	46613	1197	31	8018	98	74	1981	52	117	640	24
-11	44506	1121	32	7734	98	75	1925	52	118	625	24
-10	42506	1051	33	7461	97	76	1870	51	119	611	24
-9	40600	985	34	7199	96	77	1817	50	120	596	23
-8	38791	923	35	6948	95	78	1766	49	121	583	23
-7	37073	865	36	6707	94	79	1716	48	122	569	22
-6	35442	810	37	6475	93	80	1669	47	123	556	22
-5	33892	759	38	6253	92	81	1622	46	124	544	22
-4	32420	712	39	6039	91	82	1578	46	125	531	21
-3	31020	667	40	5834	90	83	1535	45			
-2	29689	625	41	5636	89	84	1493	44			
-1	28423	586	42	5445	88	85	1452	43			
0	27219	549	43	5262	87	86	1413	42			
1	26076	514	44	5086	86	87	1375	42			
2	249	482	45	4917	85	88	1338	41			

# HTF3000LF Temperature and Humidity Module

## Qualification Process

### Resistance to physical and chemical stresses

- HTF3000LF has passed through qualification processes of HUMIREL including vibration, shock, storage, high temperature and humidity.
- Additional tests under harsh chemical conditions demonstrate good operation in presence of salt atmosphere, SO<sub>2</sub> (0.5%), H<sub>2</sub>S (0.5%), O<sub>3</sub>, NO<sub>x</sub>, NO, CO, CO<sub>2</sub>, Softener, Soap, Toluene, acids (H<sub>2</sub>SO<sub>4</sub>, HNO<sub>3</sub>, HCl), HMDS, Insecticide, Cigarette smoke.
- ESD: HTF3000LF is able to sustain a minimum of +/- 8KV (contact discharge)

## Package Outline HTF3000LF PVH

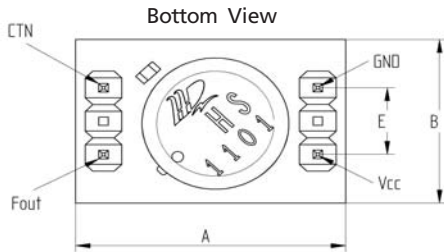

Dim	A	B	C	D	E	F
Min	17.9	12.0	12.0	14.37	4.88	1.76
Max	18.9	13.0	13.0	14.77	5.28	2.76

Dim	J	H	L	K
Min	5.6	7.2	8.0	0.54
Max	6.6	8.2	9.4	0.74

Dimensions in millimeters

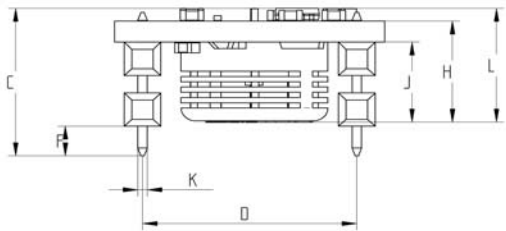

Weight: 2.1g

## Recommended Through Hole FootPrint

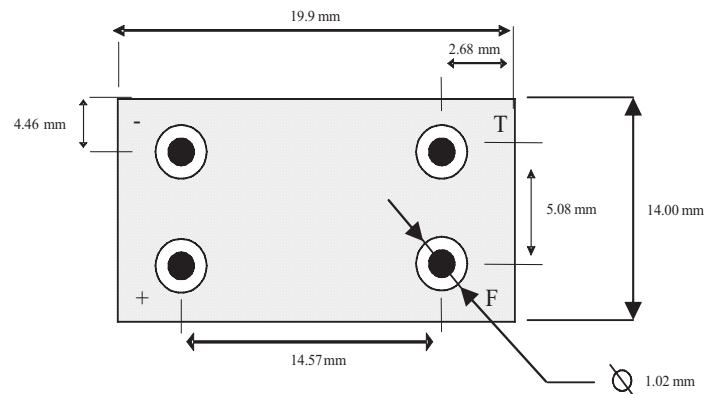
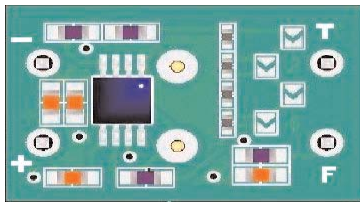

## Ordering Information: HPP808H031

# HTF3000LF Temperature and Humidity Module

## Qualification Process

### Resistance to physical and chemical stresses

- HTF3000LF has passed through qualification processes of HUMIREL including vibration, shock, storage, high temperature and humidity.
- Additional tests under harsh chemical conditions demonstrate good operation in presence of salt atmosphere, SO<sub>2</sub> (0.5%), H<sub>2</sub>S (0.5%), O<sub>3</sub>, NO<sub>x</sub>, NO, CO, CO<sub>2</sub>, Softener, Soap, Toluene, acids (H<sub>2</sub>SO<sub>4</sub>, HNO<sub>3</sub>, HCl), HMDS, Insecticide, Cigarette smoke.
- ESD: HTF3000LF is able to sustain a minimum of +/- 8KV (contact discharge)

## Package Outline HTF3000LF SMD

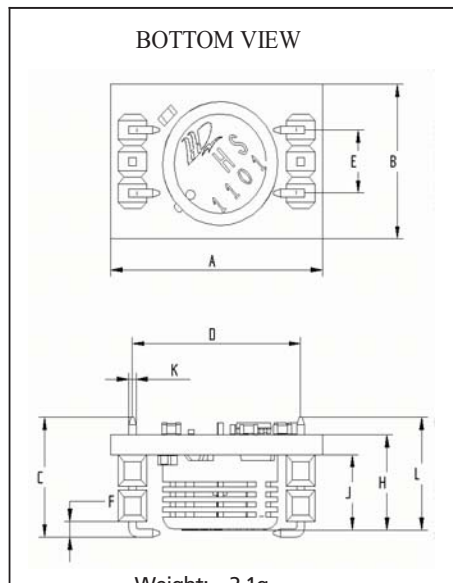

Dim	A	B	C	D	E	F
Min	17.9	12.0	9.15	14.37	4.88	0.8
Max	18.9	13.0	10.15	14.77	5.28	2.8

Dim	J	H	L	K
Min	5.6	7.2	8.4	0.54
Max	6.6	8.2	9.8	0.74

Dimensions in millimeters

## Recommended SMD FootPrint

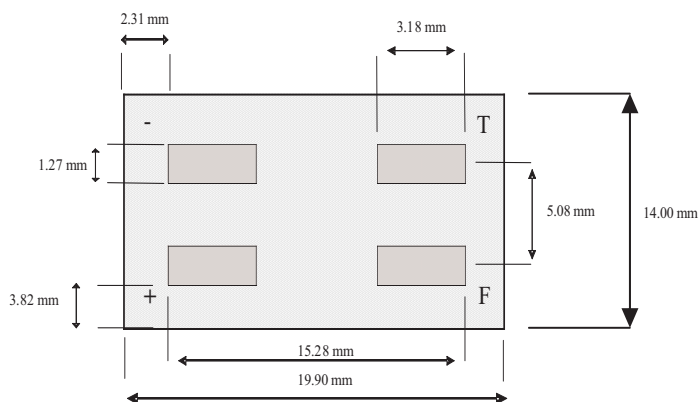
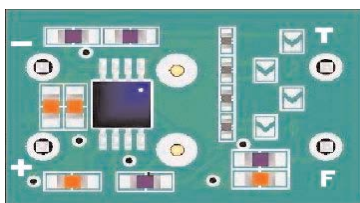

## Ordering Information: HPP808H033

## Soldering Information

### Hand Soldering:

- Temperature of the soldering iron must be kept under 350°C
- Duration of the soldering operation less than 3 seconds

### Automatic Soldering:

- Standard Tin-Lead or Lead Free Wave Soldering Process
- Recommended Reflow Profile as per Humirel specification

